

# BIL-JAX<sup>®</sup>

# 45XA



Archbold, Ohio Phone: 800.537.0540 Fax: 419.445.0367 Web: [www.biljax.com](http://www.biljax.com)

MADE IN THE  
**U.S.A.**

- **51 ft (15.6 m) working height**
- **27 ft (8.2 m) maximum outreach**
- **Dual Power (DC & Engine)**
- **Automatic leveling**
- **Platform jib & extension boom**
- **48% Gradeability**

### **Self-Propelled**

High performance 4WD system provides 3.5 mph (6 km/h) drive speed and 48% gradeability. Dual power and a narrow machine width makes the 45XA ideal for indoor and outdoor applications.

### **Lightweight**

Low point and floor loading is ideal for applications on lawns, landscaping and sensitive flooring applications. Hydraulic outriggers and automatic leveling capabilities allow users to set up and begin using lift functions in under 30 seconds.

### **Transportable**

Weighing in at only 4,715 lb (2,139 kg) operators can transport the 45XA on a utility trailer attached to a medium-duty SUV or truck. No commercial driver's license required.



# X-BOOM<sup>™</sup>

AERIAL WORK PLATFORMS

### Automatic Leveling System

A self-leveling system provides quick and easy set-up in less than 30 seconds.

### Hydraulic Outriggers

Optimized outrigger geometry provides industry leading leveling capability.

### Working Envelope and Outreach

The articulating boom design features an upper telescopic extension boom that can be positioned at a negative angle and a platform jib providing exceptional reach, working envelope, and platform positioning capability.

### Easy to Use

Both the platform and ground control station feature an easy-to-understand display panel with control buttons that are logically positioned around a single machine image.

### Versatile

A removable platform and optional material lifting system provides the ability to convert the machine into a light duty crane. An integrated 4,500-watt continuous duty generator provides AC power to the 40-amp battery charger and upper and lower GFI outlets for power on the go.

### Flexible Power System

The drive system is powered by either four 6-volt 245-amp/hr batteries or the gas engine and the lift system is always powered by batteries for convenient indoor and outdoor use.

### Standard Features

- 51 ft (15.7 m) maximum working height
- 27 ft (8.2 m) working outreach
- 500 lb (227 kg) lift capacity
- 3.5 mph (5.6 km/h) maximum drive speed
- 48% gradability
- Automatic leveling system
- 700-degree non-continuous turntable rotation
- Fully proportional control system
- 110V GFI outlet at platform and turntable
- Hour meter and battery condition indicators
- Air line to platform
- Water line to platform

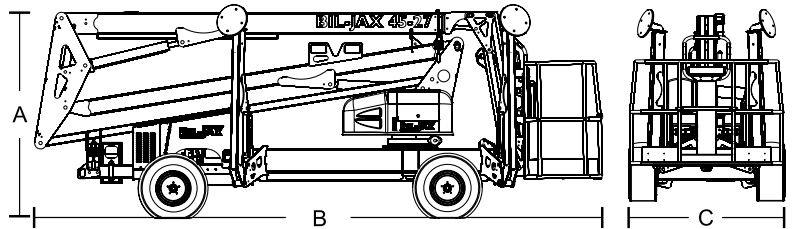
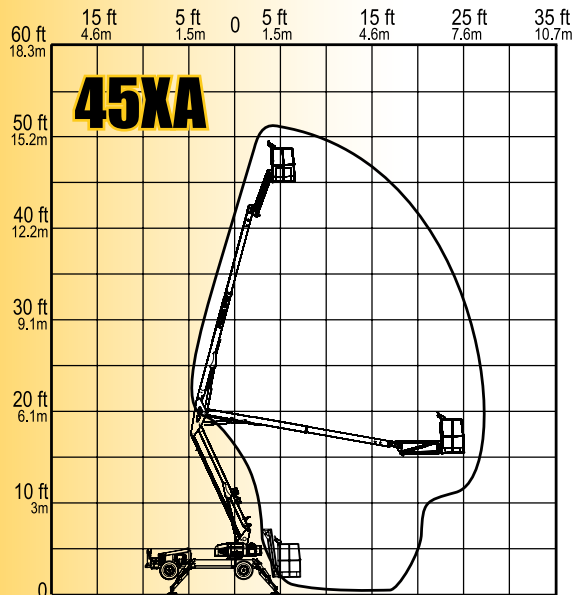

Specifications for 45XA	US	Metric
<b>Lift height</b>		
Working height <sup>1</sup>	51 ft	15.6 m
Platform height <sup>2</sup>	45 ft	13.7 m
<b>Outreach</b>		
Maximum (from centerline)	27 ft	8.2 m
Maximum (from edge of footpad)	21 ft	6.4 m
Turntable rotation	700° non-continuous	
Load capacity	500 lb	227 kg
Leveling capability	12 1/2°	
<b>Stowed dimensions</b>		
(A) Height	6ft 9 in	2.06 m
(B) Length	18 ft 3 in	5.56 m
(C) Width	5 ft 6 in	1.68 m
<b>Platform dimensions</b>		
Height - railing	43 in	109 cm
Length	30 in	76 cm
Width	60 in	152 cm
Jib length	4 ft 3 in	1.3 m
Jib vertical motion	150° (+70 / -80)	
Jib rotation (optional)	180° / hydraulic	
<b>Outrigger Footprint</b>		
Length (fully deployed)	12 ft 2 in	3.7 m
Width (fully deployed)	11 ft 3 1/2 in	3.4 m
Footpad diameter	12 1/2 in	32 cm
<b>Outrigger type</b>	Hydraulic w/Auto Leveling	
<b>Power Source</b>	24V DC and 21 HP Kawasaki Gas Engine	
<b>Batteries</b>	4 x 6V 245 amp-hr	
<b>Maximum Speed</b>		
IC power	3.5 mph	5.6 km/h
DC power	1.75 mph	2.8 km/h
<b>Gradability *</b>	48%	
<b>Wheel Base</b>	8 ft 8 in	2.7 m
<b>Turning Radius</b>		
Inside	10 ft	3 m
Outside	17 ft 6 in	5.34 m
<b>Brakes</b>	Spring Applied/Hydraulic Release (Rear Wheels Only)	
<b>Tire Size</b>	26 X 12 bar lug tires	
<b>Total Weight <sup>3</sup></b>	4,715 lb	2,139 kg

<sup>1</sup> The metric equivalent of working height adds 2 m to the maximum platform height. U.S. adds 6 ft to the maximum platform height.

<sup>2</sup> Maximum platform height when outriggers are fully extended on a level surface.

<sup>3</sup> Weight will vary depending on options and/or market destination; excludes transport trailer weight.

\* Dependent on adequate traction.

### Options

- Material lifting hook or forks
- Platform tool tray
- Hydraulic jib rotate
- Turf tires
- Non-marking tire (indoors)
- Foam filled tires

# BIL-JAX

ARCHBOLD, OH  
800-537-0540  
[www.biljax.com](http://www.biljax.com)